



THRUSTME CRUISER

INSTRUCTION MANUAL





ALWAYS REMOVE the magnetic kill switch when not using the Kicker. This is to prevent an unintentional start-up.

Warnings and advisories at the end.

After use in seawater, run the thruster in a bucket with freshwater for a short while, also clean all parts with fresh water to prolong the life of the components.

We recommend that you write down the serial number in this manual for future reference.



Serial Number: C _ _ _ - _ _ _ - _ _ _

This example will be written C006-2022-0010



Important information:

- **Before every use** check that the propeller is rotating freely and not stuck. Make sure the **magnetic kill switch is not attached** to avoid unintended startup.
If the propeller is stuck, please contact your nearest dealer. **DO NOT** try to force the motor to run, forcing it to run may cause fire in the motor.
- The unit is fully charged (to ensure max endurance).
- **Display :**
Problem: If the display don't have the correct % on the indication (or the % changes rapidly), the chip in the battery that communicates with the display are not aligned with the display.
Solution: To reset this issue, run the motor until the battery is empty and fully charge the motor again (you may need to do this 2-4 times to get the correct alignment).
This issue is most common on new motors or motors that have not been used for a long period of time .
- **Make sure you have read and understood the instruction manual before using the motor.**



Find your icon on the pages to learn more



TABLE OF CONTENTS



What's included



First time charging the Cruiser and remote



How things work



How to fit on a kayak, canoe, SUP etc.



How to charge and store the batteries



Warnings



Maintenance and service



Spare parts and extras



Warranty



Recycle and disposal



ADDITIONAL EQUIPMENT



Fast charger

INPUT : 100 -240 VAC

OUTPUT : 21V/ 10 A

Charge time internal battery 1 hour



12V Charger for Car/ Boat

INPUT : 12V - 48V DC/ 5A /50W

OUTPUT : 21V/ 2 A

Charge time internal battery 6 hour`s



Universal ThrustME tool

Tool for tightening screws or change worn parts



Propeller knife

Cuts seaweed, fishing line and other things that might get caught in the propeller

Please contact your local dealer or visit our webpage for ordering the products.

www.thrustme.no



INCLUDED



Backpack **X1**



CRUISER motor **X1**



CRUISER remote **X1**



Mounting bracket **x1**



Harness for kayak, canoe and SUP **x1**



Magnetic kill switch **X1**
(Also works as the main switch)



CRUISER charger 230V **X1**



Wrist band for remote,
with floating element **X1**



CRUISER safety cord **X1**

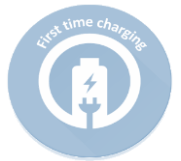

QUICK GUIDE

Congratulations with your CRUISER

For first time use – please do the following steps.

Connect the charger to the Cruiser

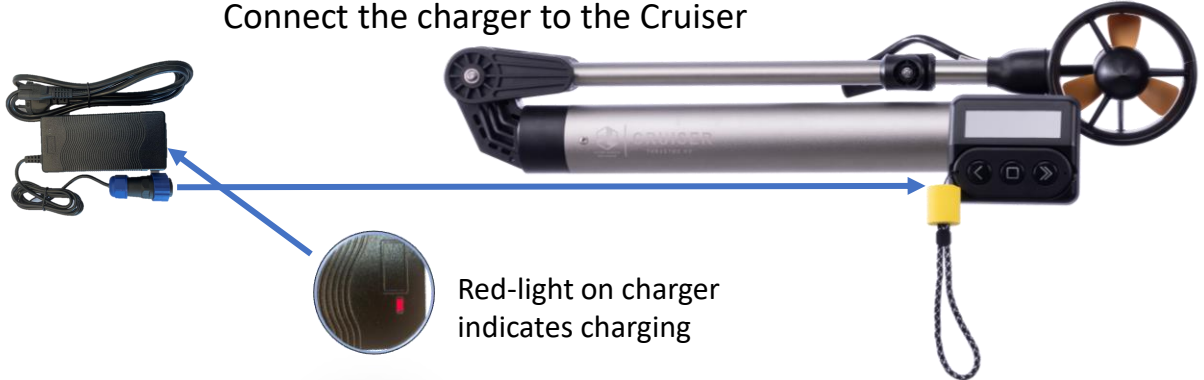

Red-light on charger indicates charging

Attach the Kill switch

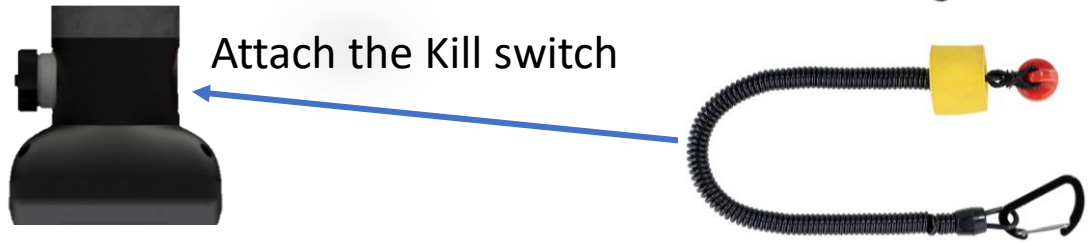

Verify that the display is ON



Insert the Remote in the Charging slot located under the display to charge the remote (kill switch) needs to be installed to charge the remote.

NOTE : The remote control can also be charged on a regular induction plate used on newer cell phones.



After 20 minutes remove the Kill switch

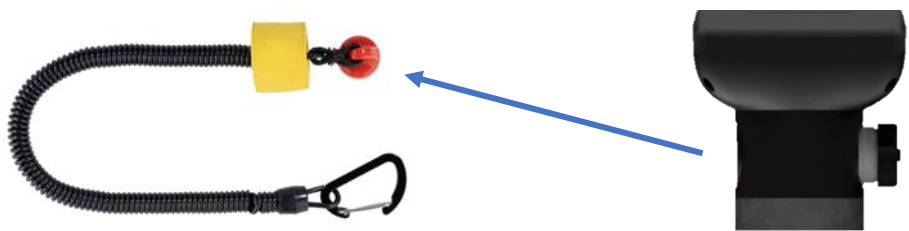

Leave the Cruiser to be charged.



Green-light Charging complete

If the Display is showing 100%, please continue charging until you have green light on the charger.

ENJOY YOUR CRUISER

MAIN FUNCTIONS

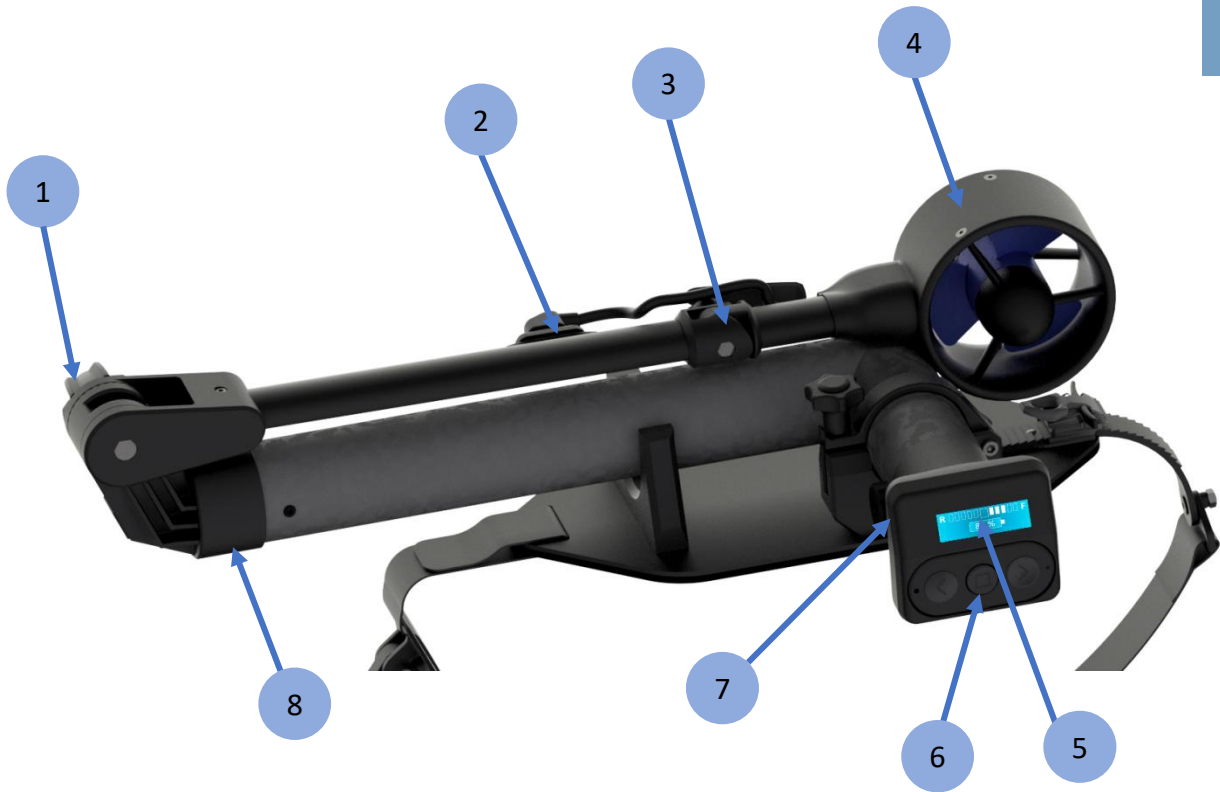

1. Upper pivot point.
2. 3-pin motor connector
3. Lower pivot point
4. Motor
5. Display
6. Wireless remote
7. Charge and external battery connection
8. Rotating swivel

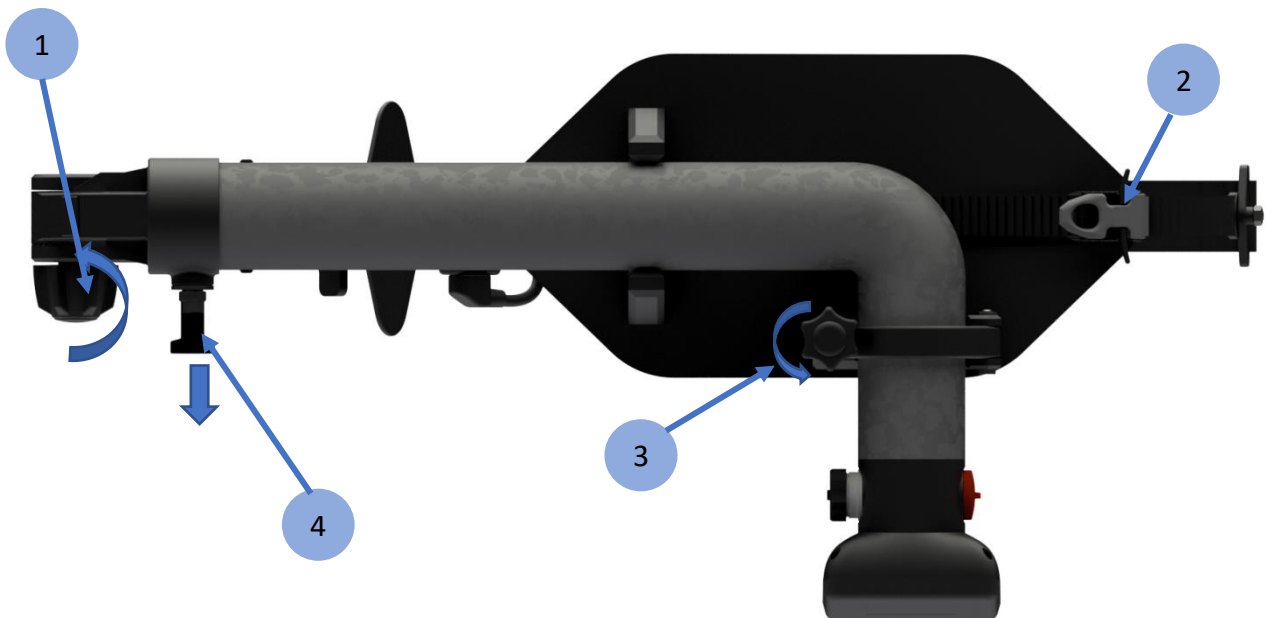

1. Pivot screw (Loosen screw before rotating)
2. Jack for fastening the main bracket to the floating device
3. Attachment screw
4. Spring pin (Pull and set in rest position before rotating)

HARNESS (jacking system)

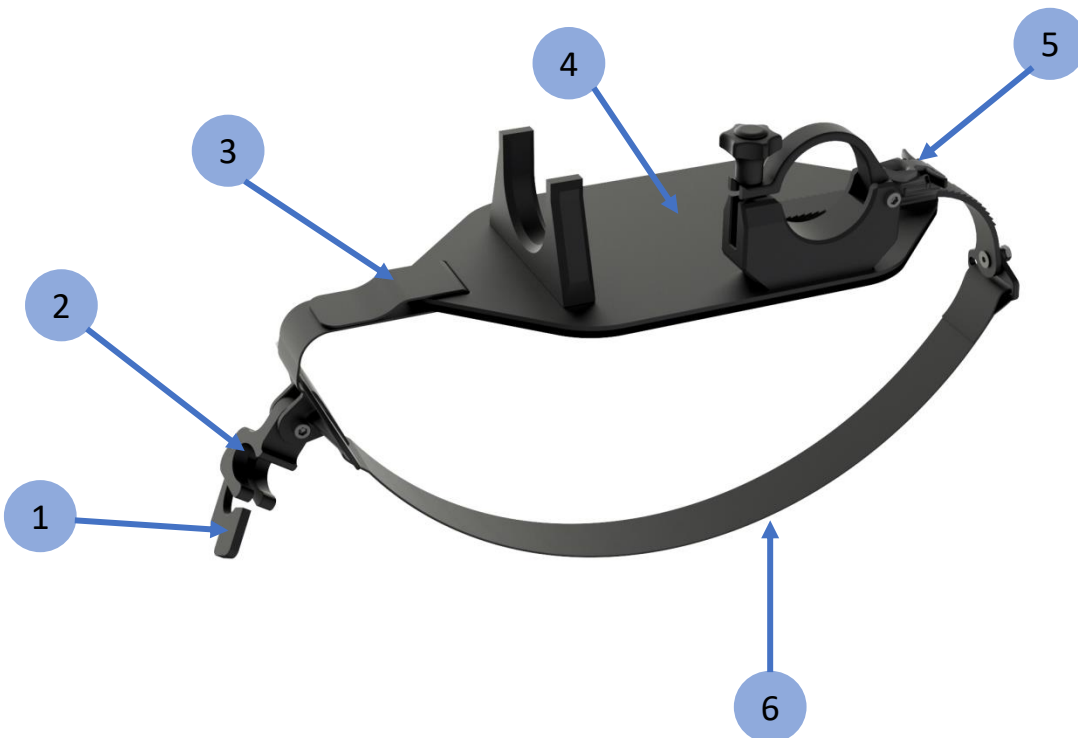

1. Moment clip/ lock
2. Moment bracket, this prevents the CRUISER to move and keeps the CRUISER steady.
(Note: place the moment bracket above water level to prevent drag)
3. Velcro for belt length adjustment
4. Attachment plate for kayak, canoe, SUP , float plane, etc...
5. Jack for adjustment and fastener for main plate (jacking system)
6. Harness for kayak, canoe, SUP, float plane, etc...

Standard Length is 190 cm, when you have found the desired length, the excess can be cut off.

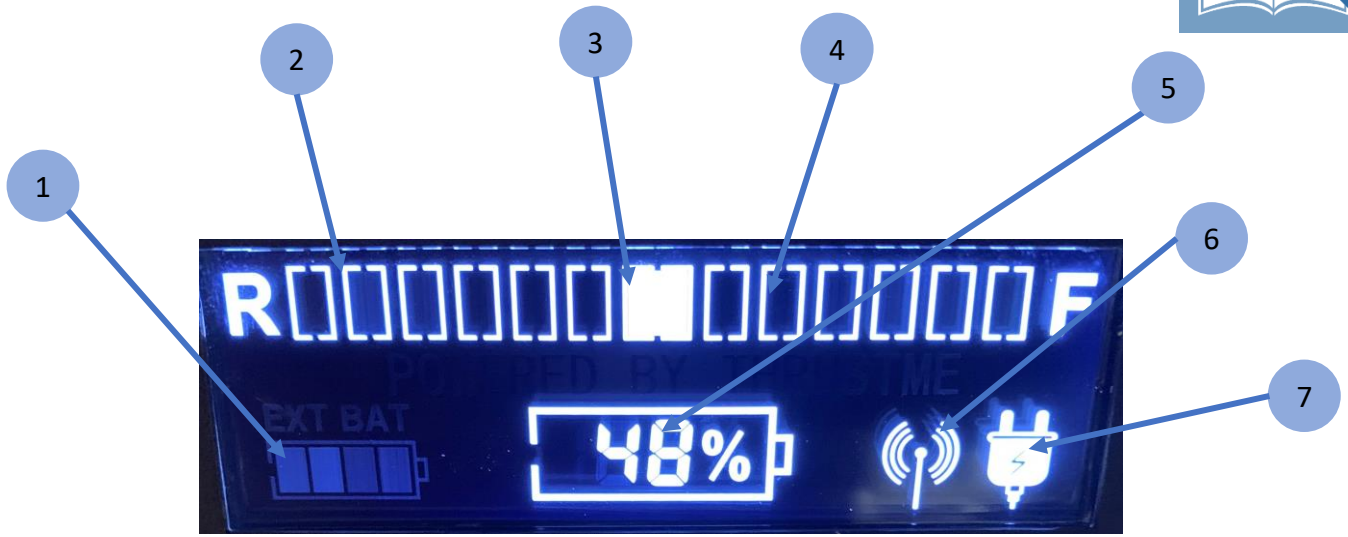

1. External battery status when connected
2. Indicator for **reverse** thrust
3. Indicator for **stop** (the motor is not running)
4. Indicator for **forward** thrust (ex. showing motor running in STEP 5)
5. Battery indicator (ex. showing 48% remaining of the battery)
6. Remote connected
7. Internal battery charging



The CRUISER is protected with an automatic circuit breaker and temperature sensors. If the motor stops while running, it needs to be reset. Before resetting check that the propeller is free for seaweed or other objects. If the battery temperature is too high, the CRUISER needs time to cool down.

Remove kill switch and re-connect for system reset.

ENDURANCE CHART

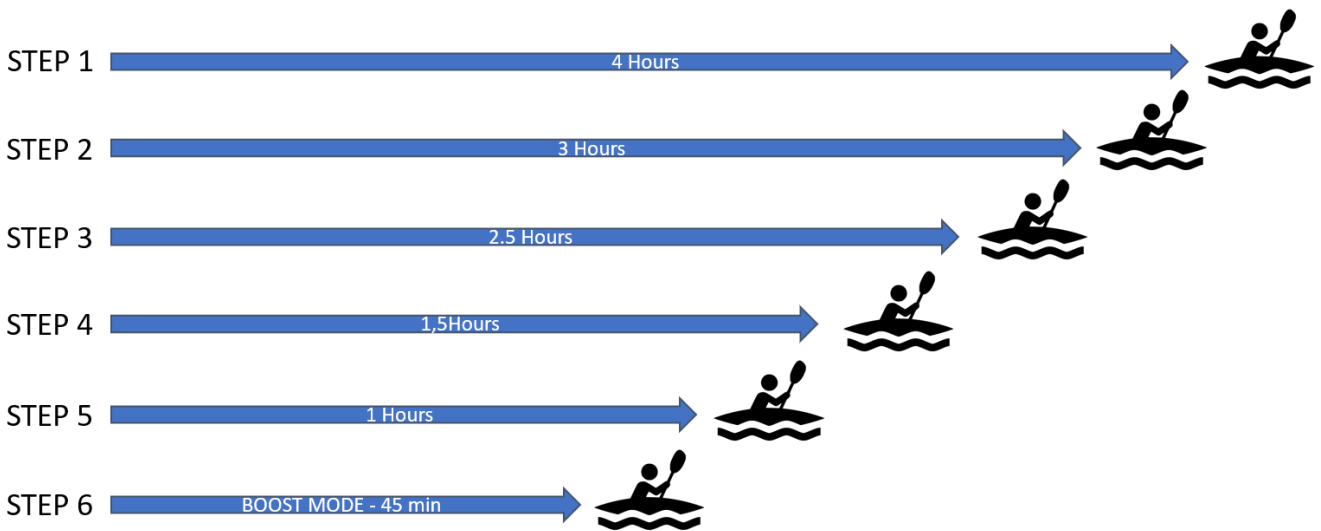

STEP 6 is a «Boost mode». When this is engaged endurance time will decrease rapidly

NOTE: This endurance chart is only a guideline; endurance may vary depending on weather, weight of cargo and persons onboard, temperature, wind and type or size of watercraft used.



1. Hole for wrist band
2. Reverse thrust (one push = one step)
3. Stop
4. Forward thrust (one push = one step)
5. Charging and indicator light, pulses while charging

To change direction you always need to push the stop button first.

NOTE: The remote vibrates when a button is pushed

NOTE: Remote is equipped with 2,4 GHz system transmitting with only 1mV, so the range is limited to approx. 75m.

When new, the remote is paired from the factory. The remote has a unique address and only one remote can control one system. If the remote is lost or not connected to the system, pairing is needed. See instructions on next page.



Read through all steps before you start the pairing mode

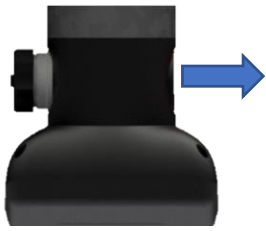

The system needs to be **turned off** for the pairing mode. (Kill switch removed)
(Kill switch needs to be in easily accessible to be used in the last part of the pairing mode.)

Revers button



Forward button

FOLLOW THE 5 STEPS TO START THE PAIRING MODE **AFTER** THE KILL SWITCH IS REMOVED



1

Press and hold reverse button after pressing the button you feel the vibration from the remote **Press and HOLD** the revers button for more than 5 seconds and **continue holding** the **reverse** for the next step .



2

Continue to hold reverse.
press and hold **forward** button in more than 5 seconds and **continue** holding for next step



3

Release Reverse button and **continue holding** the **Forward** button in more than 5 seconds



4

Wait until the blue light starts to flash, then release to forward button. **Release** forward button.



5

Attach kill switch and the system will boot up and display will no light up
The remote will pair automatically



Steady blue light after remote is paired and ready.

If the operation is not successful, please try again.



Step 1

Adjust the harness to fit your floating device.



Step 2

Attach the harness and CRUISER on your floating device, and adjust. Please make sure that the harness is tight around the floating device.



Step 3

Install the propeller in the most centre of your floating device as possible.

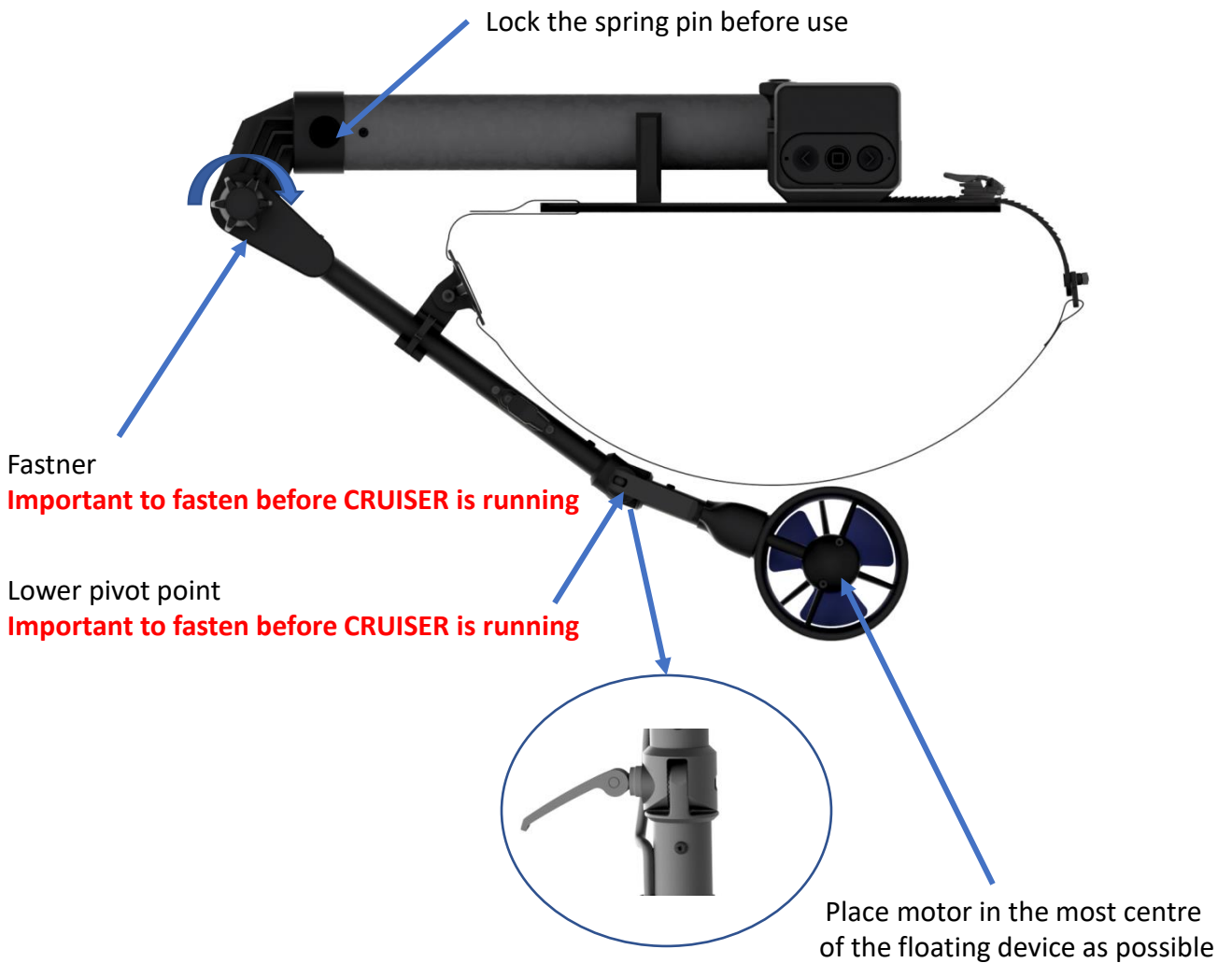



Running position



Rest position



Step 4

After all adjustments are done you are now ready to use the CRUISER .

Before you put your floating device on the water, place the CRUISER in the «rest» position or remove the CRUISER from the attachment plate.

Attach CRUISER to attachment plate when needed.

Place the CRUISER on the most suitable place before use.
(May vary between different types of kayaks, canoes and SUP)

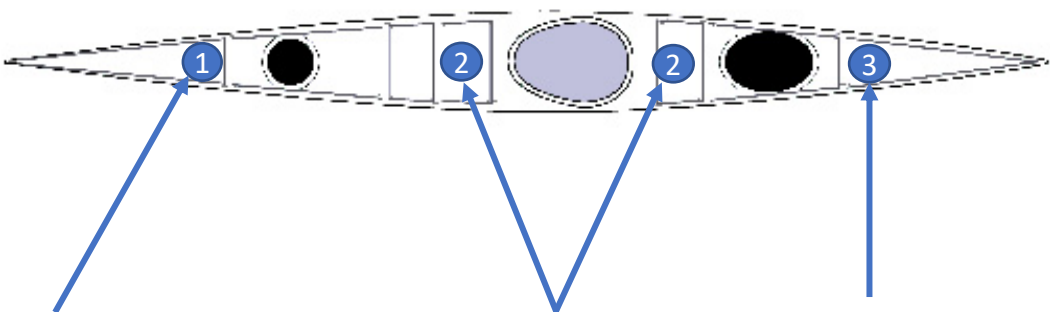

1. Front

Operator is not able to adjust the CRUISER configuration in the water. Use of handheld wireless remote is necessary

2. Centre - front/back (in front/back within reach)

Operator is able to adjust the CRUISER put in rest position.

3. Back

Operator is not able to adjust the CRUISER configuration while in the water. Use of handheld wireless remote is necessary



Make sure before starting your journey that there is no risk of running out of battery.

Watch the battery status while operating the CRUISER

CHARGING OF MAIN BATTERY AND REMOTE

Charging time 0-100%: Approx. 4 hours

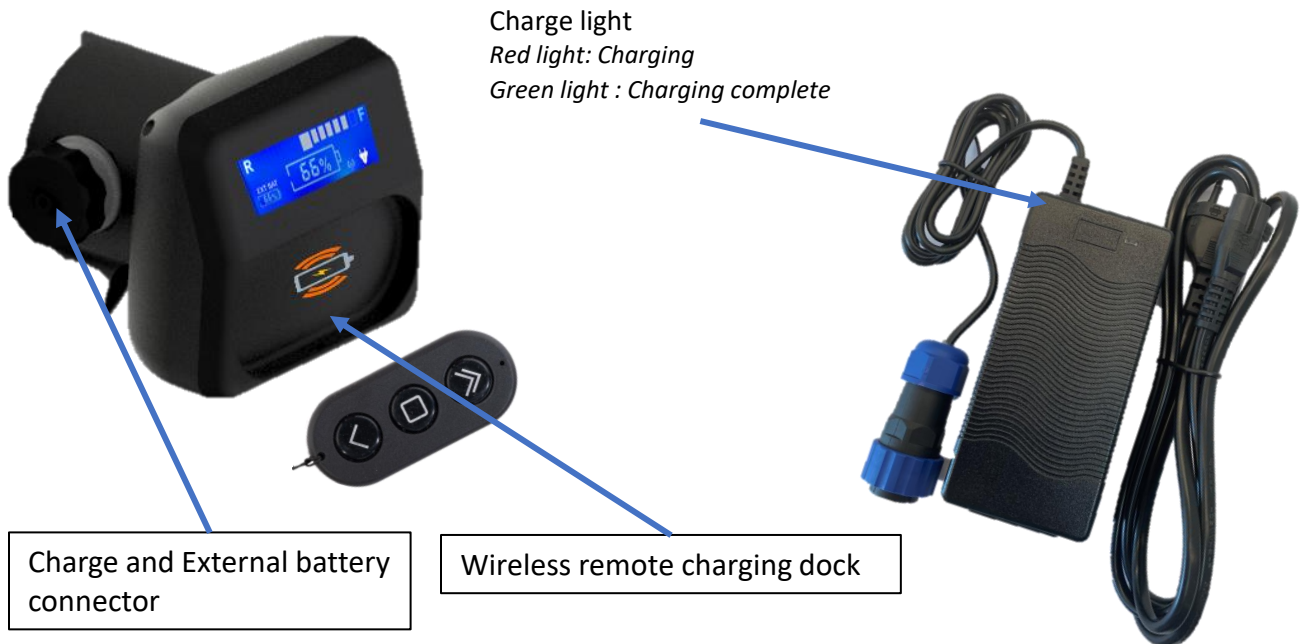

The CRUISER remote is charged by wireless charging (induction). Place the remote in the slot in the CRUISER display and the remote will be charged. Charging time: 0-100% approx. 30min

Note: Magnetic kill switch needs to be connected to charge the remote.

NOTE : The remote control can also be charged on a regular induction plate used on newer cell phones.



Always make sure **the charging connectors are dry** before use.



Only use charger provided by THRUSTME. Other chargers may damage the system or the battery.



Do not recharge the battery if the CRUISER frame feels warm and do not use the battery in temperatures above 40°C as excessive off-gassing may occur. Keep the CRUISER in the shadow when not in use and do not store in areas with temperatures above 40°C



Recharge the battery after **use within 24 hours and recharge the battery at least every 2 months**, this also applies to the remote control.



Remove the Magnetic Kill Switch when charging the unit. This is to prevent the engine from starting unintentionally. Note that the remote will not charge without the Magnetic Kill Switch attached.



Your CRUISER works with a **Li-Ion battery that needs to be handled with care.**



Always fully charge your battery before using your CRUISER.



Always fasten the protection cap to the charging connector after charging, water ingress may result in short circuit and damage of the CRUISER.



MAINTENANCE

The CRUISER is designed for minimum maintenance work, and we have made great efforts to provide you with a product with a little maintenance as possible.

The product will last longer and give you a better experience if you do the following :

After use in seawater, run the thruster in a bucket with freshwater for a short while, also clean all parts with fresh water to prolong the life of the components.

In the waters

You may experience that you get seaweed or other objects in the propeller while using the CRUISER.

If you experience change in sound or vibration, please do the following steps:



1. Remove the Magnetic kill switch to stop the motor.
2. Verify that the display is off, and motor is NOT running.
3. Tilt the CRUISER up in to rest position.
4. Remove seaweed or other objects from the propeller.





Removing/replacing propeller

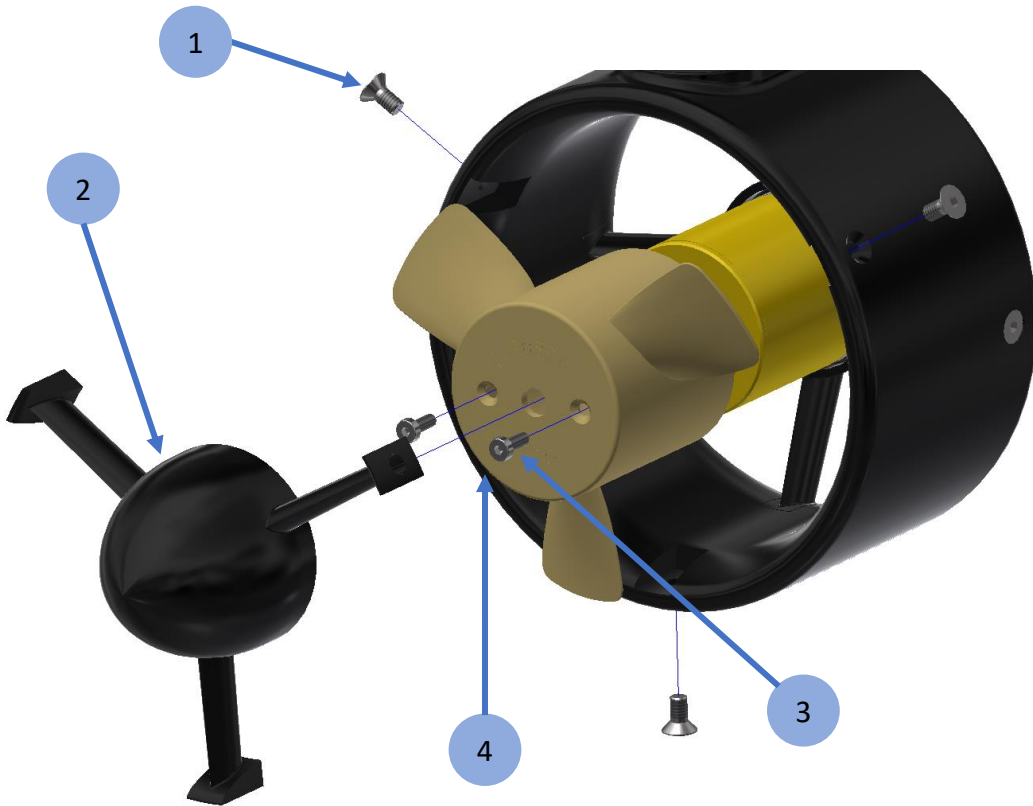

If it should be necessary to remove / replace the propeller follow steps bellow:

1. Unscrew the 3 screws and.
2. Gently remove the front bracket on the thruster
3. Unscrew the 2 propeller screws.
4. Pull off the propeller and replace the propeller

For re-installation do the following steps in reverse order:



Remember to replace all parts and make sure that everything is correct assembled and tightened.



Harness strap
Part number: C-005



Propeller CW
Part number: KC-004



Remote
Part number: KC-007



Magnetic kill switch
Part number: KC-005



Front hub
Part number: KC-009



Safety cord
Part number: KC-006



Attachment plate
Part number: C-002

WARNINGS



If the propeller is seized/stuck, do not try to start or charge the engine. Contact a service point and follow their guidelines. Do not attach the magnetic kill switch.



Do not run the motor if not in water. The motor is water-cooled and may be damaged if running without water.



Avoid seaweed or debris getting sucked into the thruster as this may damage the motor and propeller. If this occurs, please see the maintenance manual.



If used in saltwater, remember to run the thruster in **freshwater to prevent corrosion.**



Always practice caution when you are working with electricity in water and with the spinning blades of the propeller. Keep body parts away from the thruster inlet and outlet to avoid injury. **Never operate the motor if someone is in the water close to the floating device.**



Do not use the CRUISER if you suspect damage to the system or if there has been done modifications that has not been done by a certified manufacturer.



THRUSTME has the **right to refuse warranty** claims in cases where the object of purchase was in any way retrofitted, modified, or equipped with other parts or accessories not expressly approved or recommended by THRUSTME



Do not attach the magnetic kill switch to any other objects than yourself. The kill switch is for your own safety and must always be attached to yourself during operation.



Always make sure that the magnetic killswitch works before use. Persons with pacemakers is recommended to keep a distance of at least 15 cm. Do not keep cards, etc. with magnetic strip to close, this might demagnetize the card (credit/debit, etc.). The CRUISER will also affect the compass if the distance between them are too close.



Do not use the CRUISER as diving equipment or keep it submerged.



Do not store or charge the CRUISER in **temperatures below +5°C or above 40°C.**

Please make sure that you have read and understood all the warnings before you operate the CRUISER



The CRUISER uses Li-Ion battery with 259 Wh capacity, and transport via **airplane is thereby not permitted.**



It is your **own responsibility** to follow national laws and regulations.



Never use the CRUISER under influence of alcohol or other drugs.



Always bring an oar in the vessel, especially if the CRUISER is your only means of transportation. Make sure the **weather conditions** are within the margins for a safe ride, both present and future.



The CRUISER is **limited to private use and the warranty will not apply** if the product is used commercially, even if this is just of a temporarily character.



Never dry or charge the CRUISER over an open fire or other heat sources (heat gun, sun, heat cabinet, etc....). **Only charge it under adult supervision.**



Never use alcohol, gasoline, kerosene or another corrosive and chemical solutions to clean the CRUISER.



The CRUISER shall **never be used for diving.**



Always turn OFF the CRUISER when not in use (remove the magnetic killswitch), this is to prevent the engine to start unintentionally, and limiting the life span of the battery.



The CRUISER is not a toy and should never be used by persons without reading and understanding the operation manual.



Take the CRUISER **out of the water** if the vessel is driven by other means (f.eks oars, sail, towed by other boats).



Do not put fingers or other objects in the propeller while CRUISER is switched on (emergency kill switch magnet connected).

Please make sure that you have read and understood all the warnings before you operate the CRUISER



Make sure the CRUISER is turned **OFF before handling the unit out of water.** The magnetic kill switch is removed and the display is not lit. This is to prevent an unintentional start-up.



Use suitable clothes. **Do not use** wide clothes, jewellery or other items that may get caught up in moving parts, such as the propeller. Long hair must be taken care of.



Do not use any form of tool to repair, do maintenance or to modify the battery.



Prevent the battery from any contact with water or other liquids.

WARNING !

Lithium batteries can be hazardous!

- Fire or high temperature in Lithium batteries can happen.
- The battery can ventilate a lot of gas without warning.
- The battery can self ignite without warning.
- It can burn for much longer periods than more regular batteries.
- High risk of spread to other materials.
- Inhalation of poisonous smoke must be prevented.
- High temperature (do not touch).
- Small explosions in the battery cells might occur.
- If possible, try to get the battery to a place where it causes least amount of damage.
- Even if the batteries are discharged, they represent a high risk of a short circuit. Even if discharged, batteries should be handled as if they working.

Large amount of freshwater can be used to put out small battery fires (cooling effect).

Saltwater might cause the battery to explode.

Lithium fires can be hard to put out, use lots of fresh water or put the battery in a container/bucket of freshwater.

Contact doctor to treat any injuries (inhaled gas or fire damage).

Please make sure that you have read and understood all the warnings before you operate the CRUISER



The CRUISER is equipped with an internal Li-Ion battery, and even if it tested by the manufacturer in normal conditions, the product has to be **treated carefully**.



Even if the CRUISER is certified by IP67 standards (waterproof down to 1m for 30minutes), we do **not recommend to keep the product bellow water** or store it in areas with high humidity.



Do not drop, hit or do anything else to the CRUISER that might damage the battery or other components in any way.



Remove the charger when not in use, or if the battery is fully charged (100%) Only use approved charges delivered from THRUSTME, other charges might damage the systems.



Never charge a broken battery and keep it away from fire or other heat sources. Do not charge the battery in the vicinity of flammable sources that are easily flammable.



Always put the protection cap back on after charging. If not, this might lead to a broken circuit of other malfunctions.



A broken CRUISER shall not be thrown in the normal garbage but sorted as **special waste at an approved facility**.



The batteries shall **always be charged after use**. If the battery runs empty, the batter cells might get damaged.



Always check that the **charging connectors are dry** before use.



Make sure that the battery is never stored or being charged in areas with temperatures **below +5°C or above +40°C (41°F – 104°F)**.



Always store the CRUISER in a **dry environment**.



Never cover the battery or the charger while charging.

Please make sure that you have read and understood all the warnings before you operate the CRUISER



You can order all the spare parts and add-ons at your local dealership. Find your nearest dealership at: <https://www.thrustme.no/eu/dealer-locations>



All repair works shall be performed by authorized THRUSTME service centers only. Any unauthorized attempts at repair or reconstruction will result in immediate guarantee and warranty forfeiture.

Please note that opening the CRUISER main frame will result in guarantee and warranty forfeiture.

In warranty cases please read the warranty information on the next page.

WARRANTY



THRUSTME guarantees the final purchaser of a CRUISER that the product is free from material and manufacturing faults during the period stated below.

THRUSTME will indemnify the final purchaser for any expense required to repair a material or manufacturing fault. This indemnification obligation does not cover the incidental costs of a warranty claim or any other financial losses (e.g., costs for towing, telecommunications, food, accommodation, loss of earnings, loss of time etc.).

The warranty for the CRUISER (including Batteries) ends two years after original date of purchase. Final purchaser must make any warranty claim within this time period and need to submit a copy of the bill which shows the date of purchase.

Products that are used commercially or by public authorities - even if only temporarily - are excluded from this two-year warranty. In these cases, the statutory warranty applies. The right to make a claim under the warranty runs out six months after discovery of a fault. All warranty claims revert to the original date of purchase.

THRUSTME decides whether faulty parts will be repaired or replaced. Distributors and dealers who repair the CRUISER have no authority to make legally binding statements on behalf of THRUSTME. Normal wear and tear and routine servicing are excluded from the warranty. THRUSTME is entitled to refuse a warranty claim if:

- The warranty was not correctly submitted (especially failure to contact THRUSTME before returning goods, failure to present a completely filled-in warranty certificate and proof of purchase.
- The product has been used improperly.
- The safety, operating and care instructions in the manual were not followed.
- The product was in any way altered or modified or parts and accessories were added that are not expressly permitted or recommended by THRUSTME.
- Previous services or repairs were not carried out by companies authorized by THRUSTME, or non-original parts were used.

THE CRUISER IS A PATENTED PRODUCT



Before dispatching any apparently faulty goods, it is required to coordinate the delivery with THRUSTME. Please contact us via mail to: post@thrustme.no and describe the issue with your products.

Subsequently, THRUSTME support team will contact you for further steps. Please understand that we are unable to deal with products of which we have not been notified and will therefore refuse to accept delivery.

Customers are responsible to adhere to all regulations of international transport by air (IATA) and road - especially for shipping Lithium-Ion Batteries - and any customs/duty regulations. THRUSTME is not responsible for any violations of these regulations by any customer shipping. To check a warranty, claim and to process a warranty, we require your assistance: For returning the CRUISER, we recommend keeping the original THRUSTME packaging. If this is no longer available, packaging that prevents transport damage must be used (as transport damage is not included in the warranty). We are available to answer any questions regarding the warranty process - simply contact us via mail

post@thrustme.no



RECYCLE AND DISPOSAL

Thrustme CRUISER are manufactured in accordance with the WEEE Directive 2012/19/EU
This directive regulates the disposal of electrical and electronic devices to protect the environment.

WEEE is a complex mixture of materials and components that because of their hazardous content, and if not properly managed, can cause major environmental and health problems.

Moreover, the production of modern electronics requires the use of scarce and expensive resources.

To improve the environmental management of WEEE and to contribute to a circular economy and enhance resource efficiency the improvement of collection, treatment and recycling of electronics at the end of their life is essential.

You can, in line with local regulations,
hand in the CRUISER at a collecting point.
From there it will be professionally disposed.

We in the THRUSTME highly recommend you to disposal all parts for recycling for taking good care of our environment.



UKCA Declaration of Conformity

Manufacturer's name and address	THRUSTME AS (916 762 437) Veritasveien 25 4007 Stavanger NORWAY
Legal person authorized to prepare the technical documentation	Only the manufacturer can make technical documentation.
Description of the machine	Electric propulsion motor for water, with internal batteries.
Statement (4):	We hereby declare that the following Product: THRUSTME Cruiser Meets relevant requirements according to <ul style="list-style-type: none"> • Supply of Machinery (Safety) Regulations 2008 • Radio Equipment Regulations 2017 • Electromagnetic Compatibility Regulations 2016 • Electrical Equipment (Safety) Regulations 2016
Rated power	1 KW (operational power 750W)
Total Weight	3,5 kg
Battery capacity	14000 mAh
Place and date of declaration	Stavanger October 2022
Identity and signature of the person authorized to prepare the declaration on behalf of the manufacturer	

UK CA

THRUSTME AS
Stavanger
Norway

EU Declaration of Conformity

Manufacturer's name and address	THRUSTME AS (916 762 437) Veritasveien 25, 4007 Stavanger Norway
Legal person authorized to prepare the technical documentation	Only the manufacturer can make technical documentation.
Description of the machine	Electric propulsion motor for water, with internal batteries.
Statement (4):	We hereby declare that the following Product: Thrustme Cruiser Meets relevant requirements according to Machinery Directive 2006/42 / EC EEA requirements for radio equipment 2014/53 / EU Electromagnetic Compatibility - Directive 2014/30/EU Low Voltage Directive 2014/35
Rated power	1 KW (Rated power 750W)
Total Weight	3,5 kg
Battery capacity	14000 mAh
Place and date of declaration	Stavanger October 2022
Identity and signature of the person authorized to prepare the declaration on behalf of the manufacturer	 <p>THRUSTME AS Kjartan Jensen General Manager</p>



Technical specifications

Motor:

- Motor: Brushless Out-Runner
- Max Power: 1000 Watt
- Rated Power: 750 Watt
- Operation voltage: 18.5 V
- Static Thrust (forward): 16 Kg

Battery:

- Battery type: Li-ion
- Capacity: 259 Wh
- Nominal voltage: 18.5 V
- Over-discharge protection
- Over-charge protection
- Short-circuit protection
- Temperature protection

Charger:

- Input voltage: 100-240 VAC 50/60HZ
- Output DC: 21,5V
- Output current: 3,0 A



THRUSTME AS
Veritasveien 25
4007 Stavanger
Norway

www.thrustme.no



Designed and developed in Norway